

# THE HIERARCHICAL MODEL OF INTERACTION BETWEEN INTELLIGENT AGENTS IN THE MANET CONTROL SYSTEMS

Sova Oleg<sup>1</sup>, Minochkin Dmytro<sup>2</sup>,  
Polshchikov Konstantin<sup>3</sup>, Romanyuk Valeriy<sup>1</sup>

Military Institute of Telecommunications and Informatization, Kyiv, Ukraine

Institute of Telecommunication Systems, National Polytechnic University, Kyiv, Ukraine

Donbass State Mechanical Engineerign Academy, Donetsk, Ukraine

**Abstract** - The hierarchical model of interaction between intelligent agents in the MANET control systems is proposed in the paper. Proposed model is based in the conceptual representation of the intelligent MANET control systems as a hierarchical structure with vertical connections that define management tasks subordination in the MANET.

**Keywords** - mobile radio network, intelligent control system, intelligent agent, multiagent system.

## Introduction

MANET (*Mobile Ad-Hoc Networks*) [1] class mobile radio network (MRN) control features are: radio network control system (CS) consists of multiple CS nodes, that interact during the data transmission; dynamic nature of MRN leads to necessity of hierarchical architecture of their CS (master nodes and slave nodes) [2]; CS nodes make decisions based on gathering and processing of large volumes of service information about both node and entire MRN status; it is impossible to have full MRN status information in real time, therefore CS must make decisions in uncertain conditions.

MRN control process main requirement is that all management decisions for node and network resources must be carried out automatically by independent mobile nodes. Furthermore, during the management process every node's CS must consider not only its own goal function, but the goal function of all neighboring nodes [3], whose information is stored on the master node. In this scenario, MANET class radio network CS management decisions must be based on the intelligent ability to recognize and analyze different situations (on either node or network level).

Modern approach for intelligent node control system (ICS) design in view of the MANET class MRN functioning and mentioned above requirements is the use of the intelligent agents (IA) technology and multi-agent systems (MAS) [4]. Main feature of this technology is that an agent is considered as a hardware and software system, that can make decisions in uncertain conditions. That is, IA and MAS can

adapt to the changes in surrounding environment they interact with, even in the case when said changes are not defined in their behavior schemes.

There are many examples of IA and MAS used for gathering and processing information, as well as automatic management of different complex systems and processes [5]. But existing models of IA and MAS are designed using the intelligent methods that do not account for the MANET class network control features, and the lack of a method for designing corresponding models for ICS nodes delays the process of MRN development.

Therefore, the *purpose* of this article is to develop the hierarchical model for intelligent agents interaction for the MANET class radio network control system development.

## Initial data for the model

According to the concept [2], MRN ICS is an aggregation of interacting node ICS that are deployed using the IA technology [6]. In this case, IA stands for a software product able to act to achieve a given goal and in addition to the main features (reactivity, proactivity, sociality) has [7]:

Mobility – IA can carry out its functions on another node on behalf of the initiator node;

Intelligence – the main feature of IA, that presume its ability to self-learn in the process of the mobile node operations so that it can find optimal behavior patterns for cases not foreseen at the design phase.

Every IA of a node ICS is designed for a specific type tasks (performs different functions,

depending on OSI model levels) (Fig. 1), can interact with other IA for information exchange and make coordinated decisions, forming the executive layer of network ICS.

The coordination of IA operations on executive layer is managed by metaagents of

node ICS. Multiple metaagents form the node layer of network ICS. In turn, coordination of metaagents' decisions of node ICS is managed by a master node. Any node of the network can be a master node, depending on its hardware or geographic location.

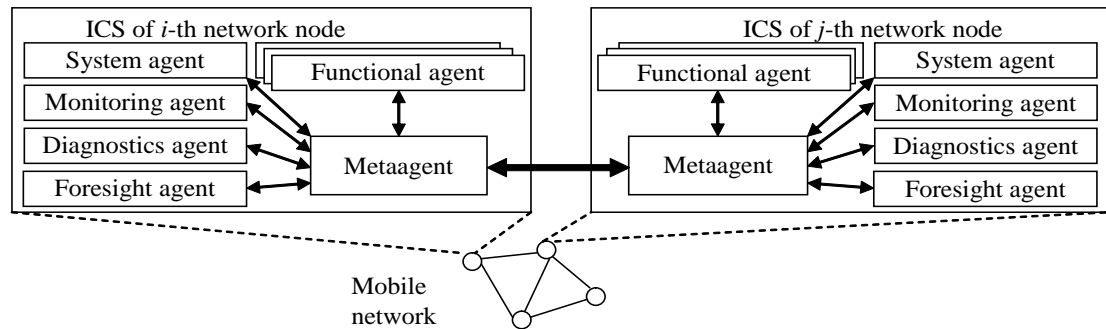

Fig. 1. Interaction of IA in the intelligent network control system

As seen on Fig. 1, main management agents of the node ICS of the network can be distinguished as follows: functional agent, system agent, monitoring agent, diagnostics agent, foresight agent. Though, the quantity and composition of IA can vary drastically depending on the network node (mobile node, base station or sensor device) [8].

*Metaagent* takes care of coordination of IA operations to achieve common management goals using the management decision made by local agents and metaagents of neighboring nodes. Metaagent analyzes network information by communicating with neighboring nodes so that it is able to make a decision to provide a certain level of QoS.

*System agent*. Its main functions are: maintaining a database of neighboring node and network status (available resources), mobile node locations (topographic information); forming a knowledge base with rules of "behavior" of the given node under different circumstances; self-learning of the mobile node.

*Monitoring agent* – implements continuous monitoring of the network key performance indicators in real time; identifies different situation on the MRN, determines current and potential problems; gathers and analyzes service information (statistics).

*Diagnostics agent* – determines, localizes and analyzes nod malfunctions; runs tests of main functions of all of the mobile node's modules.

*Foresight agent* – uses the rules and algorithms of network performance analysis on all its layers to make a forecast of node and MRN status in the near future.

*Functional agents* – implements control methods for every layer of OSI model: topology management, routing management, data streams management, queue management, message priority and security, spectrum allocation, power allocation etc.

Most of the aforementioned IA are stationary, they are located on the node permanently. But for some functions (network zone monitoring, information route planning, etc.) system agent can generate a mobile IA (MIA). MIA is relocated to another network node, collects (and processes if necessary) the information of the given node and returns to the source node with a report (or, if necessary, is relocated to a new node). MIA life cycle is illustrated on Fig. 2.

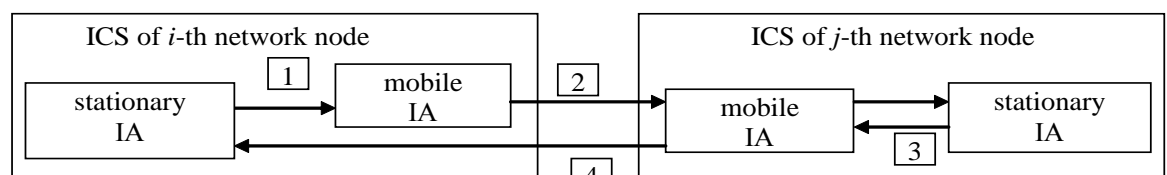

1 – node  $i$  generates a MIA, 2 – MIA relocation, 3 – data collection and processing, 4 – return to the node  $i$

Fig. 2. MIA life cycle

Therefore, in view of the hierarchical concept of network ICS design [2] and aforementioned functional structure of node ICS with IA, formal description of MANET class radio network ICS can be presented as multiple IAs on different layers, that interact with each other by exchanging service information that is used to make management decisions. To achieve this we need to solve two problems: combine heterogeneous IA in the hierarchical network ICS and set up information exchange between IA in this structure. To solve these problems an hierarchical model of IA interaction is proposed, whose structure corresponds to the hierarchical network ICS design concept.

### Hierarchical model of IA interaction

Formal description of the network ICS functional structure (with decentralized management) can be represented as a hierarchical IA structure with vertical relations between them. Given relations define the subordination of task that are resolved by IA at each layer [2]:

Zero (executive) layer – resolves management tasks according to the OSI model (routing, resource management, data streams management, security, etc.) by selecting the required values of node ICS subsystem parameters;

First (node) layer – consists of node ICS meta-agents that coordinate the zero layer IA by selecting optimal set of management actions and their implementation sequence on all node ICS subsystems;

Second (network) layer – consists of the master node that corrects the goal functions of first layer meta-agents in view of network status, as a whole, or its part.

Using graph theory we can picture the given functional structure as shown on Fig. 3. Located at the root of the tree is a master node subsystem  $(I_2, U_2)$ , at the vertices that are one edge away from the root are subsystems  $(I_{11}, U_{11}), \dots, (I_{1q}, U_{1q}), \dots, (I_{1Q}, U_{1Q})$  that

represent Q meta-agents of node ICSs. Every mentioned subsystem of network ICS contains a control (identification) block  $I$  and management block  $U$ .

In turn, every first layer subsystem  $(I_{1q}, U_{1q}), q = \overline{1, Q}$  is connected to multiple functional subsystems of zero layer  $P_{qr}, q = \overline{1, Q}, r = \overline{1, R}$ , that are located on two edges distance from the root. These subsystems represent IA interaction processes of every functional subsystem of node ICS [9]. This interaction consists of service information exchange and management decisions of each IA.

For q-th management subsystem of the first layer  $(I_{1q}, U_{1q}), q = \overline{1, Q}$  let us denote the following:

$X_{1qr}(k)$  - multiple state vectors of the q-th IA, where the size of  $X_{1qr}(k) = \{x_{1qr}^a(k)\}, a = \overline{1, a_{1qr}}$  is  $a_{1qr} \times 1$ ;

$\tilde{X}_{1q}(k)$  - multiple generalized estimated state vectors of q-th subsystem of the first layer (e.i. mobile node), where the size of  $\tilde{X}_{1q}(k) = \{\tilde{x}_{1q}^a(k)\}, a = \overline{1, a_{1q}}$  is  $a_{1q} \times 1$ ;

$U_{1qr}(k)$  - multiple management vectors of q-th subsystem of the first layer, that are directed to r-th IA of the zero layer, where the size of  $U_{1qr}(k) = \{u_{1qr}^b(k)\}, b = \overline{1, b_{1qr}}$  is  $b_{1qr} \times 1$ ;

$Y_{1q}(k)$  - multiple management vectors of q-th subsystem of the first layer, that are directed to the upper layer management subsystem (master node), where the size of  $Y_{1q}(k) = \{y_{1q}^d(k)\}, d = \overline{1, d_{1q}}$  is  $d_{1q} \times 1$ ;

$Z_{1q}(k)$  - multiple estimated state vectors of q-th subsystem of the first layer, that are directed to upper layer management subsystem (master node), where the size of  $Z_{1q}(k) = \{z_{1q}^d(k)\}, d = \overline{1, d_{1q}}$  is  $d_{1q} \times 1$ ;

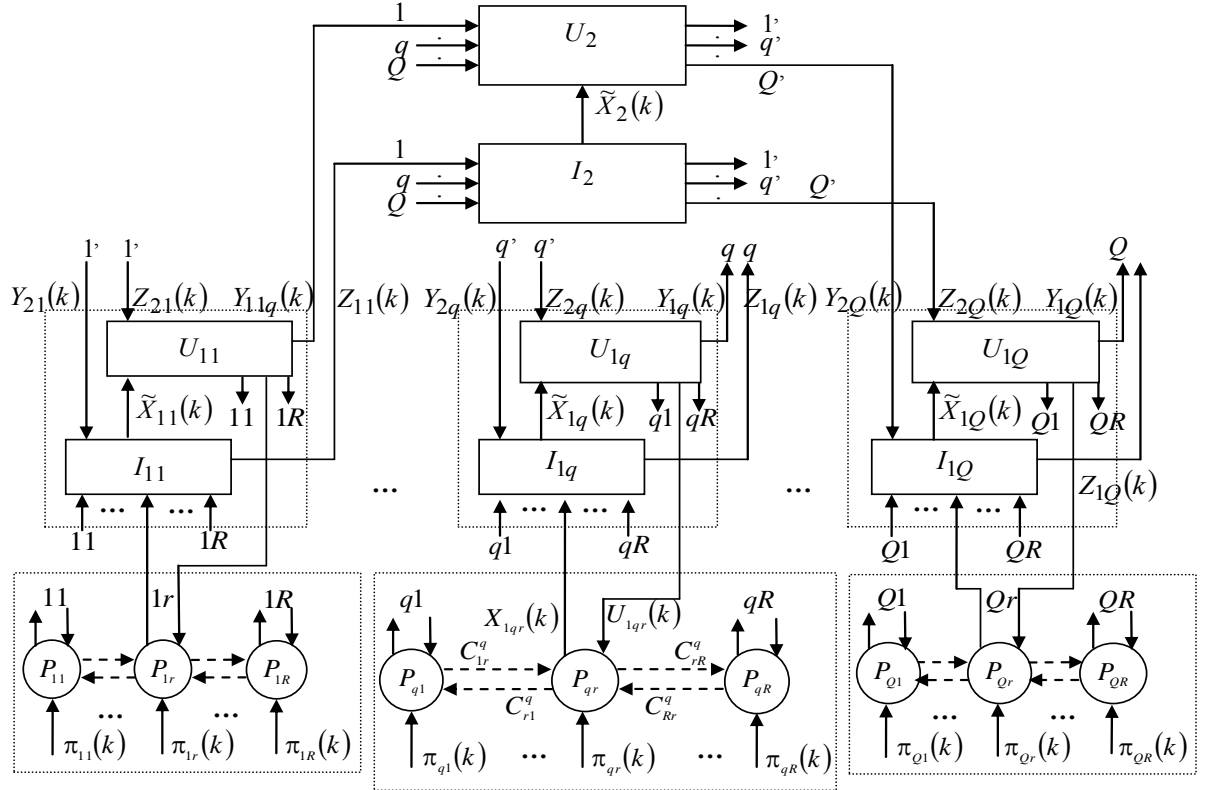

Fig. 3. Hierarchical model of IA organization of network ICS

For the second layer management subsystem  $(I_2, U_2)$  (master node), let us denote:

$\tilde{X}_2(k)$  - multiple generalized estimated state vectors of the first layer subsystems (metaagents of the node ICS), where the size of

$$\tilde{X}_2(k) = \{\tilde{x}_2^l(k)\}, l = \overline{1, l_r} \text{ is } l_r \times 1 = \left( \sum_{q=1}^Q a_{1q} \right) \times 1;$$

$Y_{2q}(k)$  - multiple management vectors of control variables, that are sent to lower layer management subsystems (metaagents of the node ICS), where the size of  $Y_{2q}(k) = \{y_{2q}^d(k)\}, d = \overline{1, d_{2q}}$  is  $d_{2q} \times 1$ ;

$Z_{2q}(k)$  - multiple management vectors of variable estimated states, that are sent to the lower layer management subsystem (metaagents of the node ICS), where the size of  $Z_{2q}(k) = \{z_{2q}^d(k)\}, d = \overline{1, d_{2q}}$  is  $d_{2q} \times 1$ ;

Finally, for  $qr$ -th subsystem of the zero layer  $P_{qr}, q = \overline{1, Q}, r = \overline{1, R}$  let us denote:

$C_{rp}^q(k)$  - multiple connections vectors (service information exchange between IA and their management decisions), where  $C_{rp}^q(k) = \{c_{rp}^{d,m}(k)\}, m = \overline{1, m_r}, n = \overline{1, n_r}$  between  $r$ -th and  $p$ -th subsystems  $(r, p = \overline{1, Q}, p \neq r)$ ;

$\Pi_{qr}(k)$  - multiple external effects vectors, that are been measured by  $r$ -th IA of the  $q$ -th mobile node, where the size of  $\Pi_{qr}(k) = \{\pi_{qr}^l(k)\}, l = \overline{1, l_q}$  is  $l_q \times 1$ .

Wherein, multiple vectors of  $q$ -th IA states  $X_q(k) = \bigcup_{r=1}^R X_{1r}(k)$  can be of different type depending on their state variables, that affect the channel quality and mobile node or network efficiency. Some of them are:

Network information load parameters vector

$$\Lambda(k) = \|\Lambda_1(k), \dots, \Lambda_q(k), \dots, \Lambda_Q(k)\|^T;$$

Information messages delays vector

$$H(k) = \|H_1(k), \dots, H_q(k), \dots, H_Q(k)\|^T;$$

Network radiofrequency environment parameters

$$\aleph(k) = \|\aleph_1(k), \dots, \aleph_q(k), \dots, \aleph_Q(k)\|^T;$$

Network spectrum resources vector

$$\Im(k) = \|\Im_1(k), \dots, \Im_q(k), \dots, \Im_Q(k)\|^T;$$

Network energy resources vector

$$\Re(k) = \|\Re_1(k), \dots, \Re_q(k), \dots, \Re_Q(k)\|^T;$$

Hardware resources vector (processor, battery capacity, RAM, etc.)

$$A(k) = \left\| A_1(k), \dots, A_q(k), \dots, A_Q(k) \right\|^T,$$

etc.

As shown in the model (Fig. 3), any q-th management subsystem of the first layer  $(I_{1q}, U_{1q}), q = \overline{1, Q}$  can be characterized by:

Mapping that describes the object being managed (metaagent of q-th mobile node)

$$O_1^{(1)}: \tilde{X}_{1q} \times U_{1q} \times C_{qp} \times \Pi_q \rightarrow Y_{1q} \times Z_{1q}; \quad (1)$$

Mapping that describes the criteria used by q-th mobile node metaagent to determine the estimated state  $V_q$  and control influence  $W_q$

$$O_2^{(1)}: \tilde{X}_{1q} \times Z_{1q} \rightarrow V_q, \quad (2)$$

$$O_3^{(1)}: U_{1q} \times Y_{1q} \rightarrow W_q; \quad (3)$$

Mapping that describes the generalized information  $\Phi_q$  that arrives to upper layer subsystem (master node)

$$O_4^{(1)}: Y_{1q} \times Z_{1q} \rightarrow \Phi_q; \quad (4)$$

Mappings that determine the constraints of input variables vectors  $\Theta_q$  and control influence vectors  $\Psi_q$ , respectively

$$O_5^{(1)}: X_{1qr} \rightarrow \Theta_q, \quad (5)$$

$$O_6^{(1)}: U_{1q} \rightarrow \Psi_q. \quad (6)$$

Second layer subsystem  $(I_2, U_2)$  can be characterized by:

Mapping that describes the formation of the generalized estimated states vector of the mobile network

$$O_1^{(2)}: \Phi \rightarrow \tilde{X}_2, \quad (7)$$

where  $\Phi = \bigcup_{q=1}^Q \Phi_q$ ;

Mapping that describes the criteria used by the  $(I_2, U_2)$  subsystem (master node) to determine the control influence destined for  $(I_{1q}, U_{1q}), q = \overline{1, Q}$

$$O_2^{(2)}: U \times \tilde{X}_2 \rightarrow W, \quad (8)$$

where  $U = \bigcup_{q=1}^Q Y_{2q}$ ;

Mappings that determine the constraints for generalized state and control vectors

$$O_3^{(2)}: \tilde{X}_2 \rightarrow \Theta, \quad (9)$$

$$O_4^{(2)}: U \rightarrow \Psi. \quad (10)$$

The functioning of the ICS of all mobile network elements (mobile or sensor nodes, mobile base station or network control center)

[9] can be described by time intervals, as follows:

$T_{1q}$  - time interval for performing management and control tasks (1 – 6) by metaagents of every node ICS  $(I_{1q}, U_{1q})$  subsystems);

$T_{1q}^{(2)}$  - time interval of generalized information transmission from metaagents  $(I_{1q}, U_{1q})$  to the master node  $(I_2, U_2)$  subsystem);

$T_2$  - time interval for performing the control and management tasks (7 – 10) by the master node;

The length of  $T_{1q}$  time interval is determined by the external influence vector  $\Pi_{qr}(k)$  change rate, change of the control influences  $Y_{2q}(k)$  and  $Z_{2q}(k)$  from the master node  $(I_2, U_2)$ , and the change of interconnection matrix  $C_{rp}^q(k)$  structure. The length of  $T_{1q}^{(2)}$  time interval is determined entirely by the methods and protocols of interaction between  $(I_{1q}, U_{1q})$  and  $(I_2, U_2)$  subsystems, defined at appropriate levels of the OSI model.

Based on the information received by node ICS metaagents  $(I_{1q}, U_{1q}), q = \overline{1, Q}$ , the master node  $(I_2, U_2)$  checks the restraints (9), (10) and calculates the values of the indicator in (8) with control influences  $U(k) = \{U_{1qr}(k)\}$ , that are defined by subordinate node ICS on the previous time interval. If constraints are observed or a criterion has a deviation from the required value, a higher layer task is performed again, which defines the length of time interval  $T_2$ .

For a three layered network ICS (Fig. 3) the ratio between the aforementioned time intervals is as follows [9]:

$$T_2 \geq T_{1q}^{(2)}, T_2 \gg T_{1q}, T_{1q}^{(2)} \geq T_{1q}, \text{ for } \forall q = \overline{1, Q}.$$

During those time intervals every element of the network ICS implements corresponding methods and algorithms of mobile network management, from mathematical methods and algorithms of link management (physical level of OSI model) to methods and algorithms of application level management (security management, power consumption management, QoS management, etc.).

## Decision making in the network intellectual control system

In the general scenario, management decision making in the network ICS means providing a given quality of information exchange in MANET by determining the values of control variables of node ICS based on the analysis of current state of the radio network. But, as mentioned before, every node ICS is characterized by its own goal function, that is formed based on multiple factors:

Resources and hardware/software capabilities of the node, i.e. the totality of the devices for reaching the goal (RAM, processor performance, battery capacity, etc.);

Managed parameters: on physical level – transmitter power, modulation, transmission rate, etc., on channel level – access protocol, on network level – routing method, on transport level – transfer method, etc.;

Uncontrollable parameters: set exchange protocols, topology dynamics, network size, interference level, etc.;

Requirements for information exchange quality for different types of traffic (data, voice, video, graphics).

It leads to the inability to achieve global optimization of the entire mobile network in the case of decentralized management environment and with presence of contradiction between the optimal node ICS awareness and the timeliness of control influences. Thereby, it was proposed in [10] to decompose the main goal of mobile network management to multiple simpler goals. To achieve this, in the design phase of node ICS a goal structure (GS) is formed as a graph, where the vertices are goals, and edges are the influences of achieving a goal in a subgoal (Fig. 4).

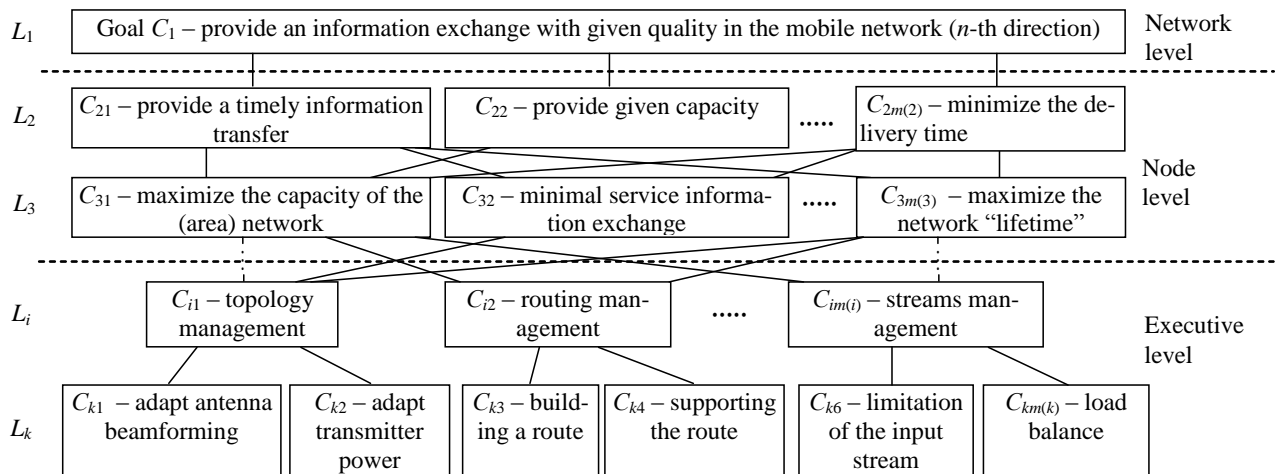

Fig. 4. Fragment of the goal structure of the network ICS

In the previous research it was shown, that in an uncertain environment, where a mobile network functions, to describe a situation and make a management decision by the subsystems of node ICS it is advisable to use the methods of fuzzy logic [11]. Therefore, the goal structure (Fig. 4) can be mathematically interpreted as a list of fuzzy management goals of different levels  $L_1, \dots, L_k$ , that are connected by [10, 12]:

$$\begin{aligned} \text{GS} = \{ & C_1, R_{2m(1)} \{ C_{21}, C_{22}, \dots, C_{2m(2)} \}, \\ & R_{3m(2)} \{ C_{31}, C_{32}, \dots, C_{3m(3)} \}, \dots, \\ & R_{km(k)} \{ C_{k1}, C_{k2}, \dots, C_{km(k)} \} \} \end{aligned} \quad (11)$$

where  $C_1$  – global goal of the network ICS, that is determined by the master node;  $C_{il}$ ,  $i = \overline{1, k}$ ,  $l = \overline{1, m(i)}$  –  $l$ -th subgoal of  $i$ -th level of the goal structure, that is determined by the metaagent of

the corresponding node ICS;  $R_{ij}$ ,  $i = \overline{1, k}$ ,  $j = \overline{1, m(i-1)}$  – fuzzy relationship between the lax advantage of the objects on the  $i$ -th level over every object at the upper  $i-1$  level.

If  $R_{ij}$  describes the relationship only between the subgoals of neighboring levels, we should talk about a goal tree, otherwise the goal structure degenerates to a network.

Let the goal system consist of  $k$  levels and every  $L_i$  level  $i = \overline{1, k}$  consists of  $m_i$  objects (for first level  $m_1 = 1$ ):

$$L_i = \{ C_{i1}, C_{i2}, \dots, C_{im(i)} \}.$$

Goal structure (Fig. 4) can be described as a multiple of levels  $L_i$ :

$$\text{GS} = \bigcup_{i=1}^k L_i = \bigcup_{i=1}^k \bigcup_{l=1}^{m_i} C_{il}.$$

As seen on Fig. 4, different elements of the goal structure are united under a global goal  $C_1$ , that can be described as providing the information exchange with given quality in the network. As mentioned before, a binary fuzzy relationship of a lax advantage  $R_{ij}$  is used to describe the relationship between global goal and lower level goals, that is given by a membership function  $\mu_{R_{ij}}(C_{il}, C_{ir})$ ,  $i = \overline{2, k}$ ,  $j = \overline{1, m_{(i-1)}}$ ,  $l, r = \overline{1, m_i}$ .

It should be noted, that depending on the hierarchy layer (Fig. 3) there can be two types of relationship:

“goal - subgoal” relationship – appear between the elements of the network and node layers (between master node and subordinate nodes of a mobile network or its area) and create a goalforming part of the GS;

“subgoal – means to reach the goal” relationship – appear between elements of the node layer (metaagents of node ICS) and the elements of the executive layer (IA of corresponding functional subsystems) and create an implementing part of the GS.

And so, beginning with the second hierarchy layer (11), at every  $i$ -th layer there are as many fuzzy relationship of advantage  $R_{ij}$  as there are objects at  $i - 1$  level of GS. In the general case, these relationships can be described as a matrix:

$$R_{ij} = \begin{pmatrix} 1 & \mu(C_{i1}, C_{i2}) & \dots & \mu(C_{i1}, C_{im(i)}) \\ \dots & 1 & & \dots \\ \mu(C_{im(i)}, C_{i1}) & \dots & & 1 \end{pmatrix}$$

where  $\mu_{R_{ij}}(C_{il}, C_{ir}) \in [0; 1]$ ,  $i = \overline{2, k}$ ,

$$j = \overline{1, m_{(i-1)}}, l, r = \overline{1, m_i}.$$

As a result, tasks of decision making of the network ICS are reduced to receiving of the priority vector of the lower layer elements in relationship to the global goal – the element of the first layer. To cope with this task in [12] it is proposed to use a weighting procedure of the hierarchy analysis method or fuzzy relationship convolution algorithm.

### Conclusion

Thereby, to respond to the features of the management in the MANET class mobile networks, the management system must have intellectual capabilities to recognize and analyze the situations in the radio network, and based on

this, make management decisions to control the node and network resources. To design such management system it is proposed to use the technology of intellectual agents and multiagent systems, that suggests that all subsystems of node ICS are implemented using multiple IA, that are defined by management functions depending on the level of the OSI network model.

To combine different IA in an intellectual network control system a hierarchical model of IA interaction was proposed in this article, whose essence lies in describing the network ICS as a hierarchical structure with vertical links, that indicate the subordination of management tasks.

The novelty of the model lies in using the graph theory to make a formal description of the functional subsystems of the network ICS (vertices of the graph) and their interaction processes (edges of the graph). Using the proposed model can accelerate and systemize the network design process considering their functioning environment and hierarchical structure of their ICS. Using the intellectual agents technology and multiagent systems allows to minimize the service traffic and use network and node resources more efficiently.

During future research a model for information resources organization of network ICS will be developed, to describe the circulation, processing and storage of the service information, that is used by the methods and protocols of corresponding subsystems for making management decisions in the mobile network.

### References

1. Conti M. Mobile ad hoc networking: milestones, challenges, and new research directions / Conti M., Giordano S. // Communications Magazine, IEEE. – Vol. 52, Issue 1. – P. 85 – 96.
2. Concept of hierarchical design of intelligent control systems of MANET class tactical radio networks / [Sova O., Romanyuk V., Zhuk P., Romanyuk A.] // 22<sup>nd</sup> international conf. “UHF and telecommunication technologies” Crimico-2012. – Sevastopol: Crimico – 2012. – pp. 265 – 266.
3. Romayuk V. Target functions of operational control of tactical radionetworks / Romanyuk V. // Collection of scientific work of MITI NTUU “KPI”. – 2012. – № 1. – pp. 109 – 117.
4. Russel S. Artificial intelligence. A modern approach / Russel S., Norvig P. – Williams, 2007. – 1408 c.
5. Bugaichenko D. Design and implementation of methods considering formal and logical

- specifications of self-tuning multiagent systems with time constraints: PhD thesis : 05.13.11 / Bugaichenko Dmitrii Yurievich. – SPb., 2007. – 259 p.
6. Analysis of possibilities of intelligent agents usage for building the node control systems for MANET / [Sova O., Simonenko O., Romanyuk V., Umanec Y.] // Collection of scientific work of MITI NTUU “KPI”. – 2013. – № 1. – p. 76 – 84.
  7. Gavrilova T. Knowledge bases of intelligent systems / Gavrilova T, Horoshevski V. – SPb.: Piter, 2000. – 384p.
  8. Romanyuk V. Architecture of MANET control systems / Romayuk V., Sova O., Zhuk O. // Conf. “Problems of telecommunications - 2011”. – K.:ITS NTUU “KPI” 2011. – p. 77.
  9. Minochkin A. Objective, multiagent model of operational control of mobile component of a new generation military network / Minochkin A., Shacilo P. // Collection of scientific work of MITI NTUU “KPI”. – 2008. – № 3. – pp. 107 – 118.
  10. Minochkin A. Methods of decision making in a mobile radio network control system / Minochkin A., Romanyuk V. // Collection of scientific work of MITI NTUU “KPI”. – 2006. – № 1. – pp. 66 – 71.
  11. Methods of processing the knowledge about a situation in MANET network for building intelligent node control systems / [Sova O., Romanyuk V., Minochkin D., Romanyuk A.] // Collection of scientific work of MTI STU. – 2014. – № 1. – pp. 97 – 110.
  12. Blumin S. Methods of decision making in an uncertain environment / Blumin S., Shuikova I. – Lipetsk: LEGI, 2001. – 138 p.