

DIRECTIONS OF MOBILE AD HOC NETWORKS EFFICIENCY INCREASE

Valeriy A. Romanjuk, Oleg Ya. Sova

Military Institute of Telecommunication and Information of the State University of Telecommunication,
Kyiv, Ukraine

The directions of efficiency increase of the self-organizing wireless networks MANET are proposed. They consist in the implementation of new methods and radio network management functions, coordination and intellectualization of the methods, corresponding to different OSI-model levels, and also coordination of the network resource management purposes distribution.

Introduction

Mobile Ad Hoc Network (MANET) is a type of ad hoc network that can change locations and configure itself on the fly. Distinctive features of MANET are network self-organization, dynamic topology, decentralized control and heterogeneity of network elements. Advantages of the MANET are easy nodes configuration into the network, lack of network infrastructure, high survivability, work on the motion of all the network elements etc (table 1). Exactly these features have been attracting the attention of scientists to the development and improvement of the MANET in recent years.

Table 1. MANET advantages and disadvantages

Advantages (+) Disadvantages (-)	Due to what can be achieved (improvement directions, disadvantage elimination), effects
(+)	Ability to self-organization, rapid deployment, extension, renewal.
(+)	High survivability.
(+)	High network efficiency.

	<p>the OFDM and MIMO technologies; application of ultra-wideband impulse signals (IR-UWB) [2] etc.</p> <p>2. <i>At the link layer of OSI model</i> – effective link-layer protocols using (for example, to ensure quality of service (QoS) in the channel).</p> <p>3. <i>At the network layer of OSI model</i> – effective network layer protocols use (for example, to ensure QoS routes, multipath routing, etc.) [2]; introduction of additional network topology control sub-layer.</p> <p>4. <i>At the transport layer of OSI model</i> – effective flow control protocols use.</p> <p>5. <i>At the application layer of OSI model</i> – OSI layers coordination and integration, using of intellectual network management methods [2].</p>
(+)	Different traffic types transmission.
(+)	High Security.
(-)	Significant volume of service traffic.
(-)	A small direct connection distance.
(+)	High hindrance protection.

There are two ways of the MANET creation today:

- modernization of existing narrowband radio networks through the implementation of the developed MANET operation algorithms (protocols), which will improve the performance of existing radio networks under certain restrictions on the number of subscribers and the speed of their movement, traffic intensity and so on;

- creation of modern broadband, multiband, high-speed, programmable, multi-channel (multiple transceivers) and cognitive of radio facilities, which allow to provide the high channel capacity, plug-and-play mode and the possibility of network self-organizing, intellectual and decentralized network resources management, all traffic types transmission, work on the move, low power consumption and so on.

Analysis of recent publications has allowed us to determine an approximate gain (in arbitrary units) of the wireless networks performance (table 2) in case of various technologies and methods use.

Table 2. Approximate gain (in arbitrary units) of the wireless networks performance in case of various technologies and methods use

Problem	Technology (decisions methods)	Gain
Radio channels bandwidth increase	Band shifting (hundreds of MHz, units of GHz), optical range using. Radio spectrum optimization. Directional antenna use.	10 2...20 2...30
Routing	New hybrid routing protocols use.	2...5
Additional architecture elements	Mobile base stations, unmanned aerial vehicles.	2...4
Network resources management	Radio network management intellectualization.	3...5

However, creation of the MANET requires solving of many scientific problems associated with decentralized network management (routing, radio resources allocation, power management, topology management, information security, QoS and so on) with limited resources of mobile radio terminals [1]. In this paper directions of mobile ad hoc networks efficiency increase are discussed.

New approaches to the MANET functioning

The purpose of the MANET creating is to provide quality communications to subscribers according to the principle "in any place – at any time". Moreover, despite the dimension of MANET, radio network should provide throughput, reliability and speed of message delivery comparable with the wired networks.

For ensuring of these indicators a fundamentally new approaches to the functioning of MANET are offered.

1. Packets relay "on the fly"

Each packet in all nodes of the route goes through the following processing procedure (Fig. 1): setting in the queue, processing at three OSI levels, adding the titles, re-setting in the queue at network and data link layers, insert new data into the headlines, the organization access to the channel with mandatory acknowledgments (and possible retransmission). This leads to considerable delays in data transmission on the route from sender to addressee.

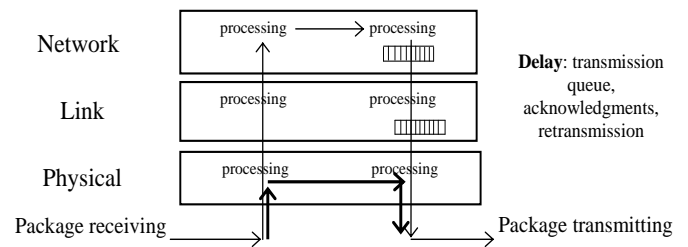

Fig. 1. The proposed processing scheme

The proposed processing scheme consists in time reducing, that is expended to process packets on intermediate nodes. Packet header is processed only at the physical layer without the involvement of data link, network and transport layers. In this case, the routes between sender and the addressee must be built using principles of the MPLS-protocol. Address and route label (located at the top of the header) are analyzed at the physical level. If node isn't the addressee, it is re-transmitting the packet on the route. The solution consists in combining the functions of reception and transmission so while the first parts of the packets are transmitted the other parts are receiving. The benefits are obvious, but this approach requires advance channel resources reservation in routes of transmission.

2. Network topology management

Network topology determines the potential for data flow transmission through the network. It is proposed to introduce an additional sub-layer of the OSI model network layer to control the topology of the network by changing the transmission power and (or) radiation pattern of the antenna (Fig. 2). It can get different topologies with different potential bandwidth and a route length.

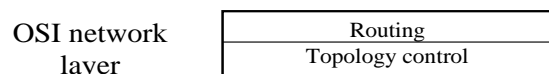

Fig. 2. Partition of the OSI network layer at sub-layers

Increase (decrease) in the transmit power increases (decreases) the number of "neighbor" nodes and reduces (adds) the number of relay on the routes, but extends (reduces) the zone of mutual interference (the "hidden terminal" problem) thus reduces (increases) the radio channels bandwidth and require larger (smaller) battery energy consumption of nodes. There is a certain optimum of network parameters when managing network topology [10].

3. Implementation of the OSI-transport layer using route division into segments

This approach allows reducing the number of interrupted sessions at the transport layer by decreasing the number of route reconstructions due to changes in network topology.

4. Parallel multiple packets retransmission

At the network level parallel packet transmission can be carried out by multipath routing, which involves the construction of several independent routes and load balancing between them [12]. However, this leads to significant volumes of service traffic. In order to improve the reliability of transmission and channel capacity it's proposed using of a parallel packet transmission at the physical level, called cooperative diversity. Nodes simultaneously retransmit the same packet on different frequencies/channels to be diversity combined at receivers. Another way to implement parallel multiple packets retransmission is antenna array use where nodes act as elements. In general, using the parallel transmission at the physical level significantly improves SNR at the reception.

5. MANET intellectualization

Increasing the network dimension leads to a significant service traffic increasing (volume of service traffic grows at least quadratically to the network dimension). Therefore, possible solution for service traffic reduction is to create intelligent (intellectual) network control system, as a set of the interacting intellectual nodal control systems (Fig. 3).

To make decisions of the node and network resources management, intellectual nodal control system should collect information about the network and take into account the quality of service requirements for particular traffic type. Therefore, the main architectural feature that distinguishes the proposed intellectual control system built on the "cognitive" scheme lies in presence of a decision making subsystem, consisting of a knowledge base (contains information about the objectives of the nodal control system, as well as rules of decision on the choice of node "behavior"), database,

logical inference unit and the network resources models base [11, 13].

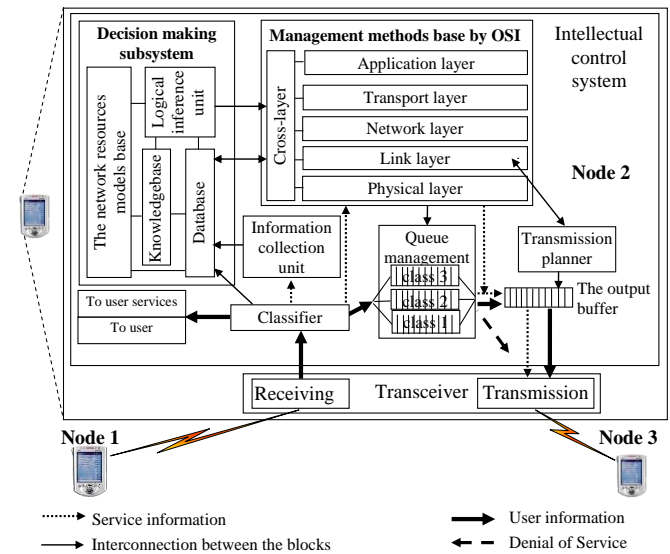

Fig. 3. Architecture of intellectual nodal control system

Decision making subsystem coordinates the operation of management methods, combined in a management methods base by OSI layers, to optimize the MANET performance function. The peculiarity of the proposed approach is that coordination and integration between OSI layers are carried out not only according to different parameters, but also according to management objectives that define a particular control method at each OSI layer.

In general, intellectualization of nodal control system ensures adaptation of the node to the MANET conditions, which are characterized by uncertainty of radio medium. For construction such a control system is proposed to use the intelligent agent technology.

6. OSI levels coordination

Existing approaches to the telecommunication networks design assume independence of control functions by OSI levels (Fig. 4a). However, this approach does not take into account the features of MANET and does not allow optimization of the performance indicators at every OSI layer (or in general) under various network conditions and the requirements of a particular traffic type (eg, video or audio) [9].

Making a decision at some level of the OSI model can be based on service information collected at other levels. Service information from different OSI levels, which has been analyzed by nodal knowledge base, provide more accurately assess of the radio network current state and reduce the volume of service traffic that is transmitted to the MANET. In addition, it will allow optimal use of nodal and network resources

(bandwidth of the radio channel, battery capacity, nodal processor power, memory capacity etc.) during the routes searching and information transmission.

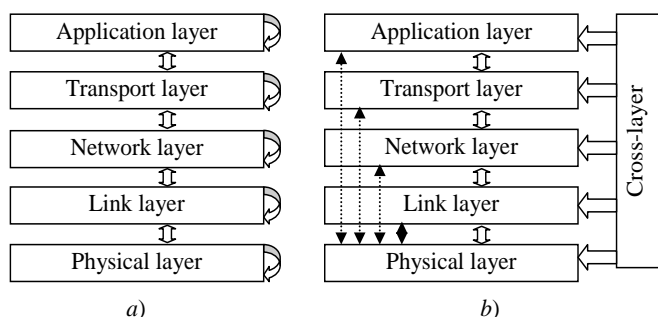

Fig. 4. OSI architecture (a) and coordinating (cross-layer) architecture (b)

7. Matching management objectives for network resource distribution

Under the decentralized control conditions each nodal intellectual control system will implement two groups of objectives – user and network (zone) objectives.

User objectives are to achieve the desired quality of transmission and optimization parameters of the nodes in a certain direction between the sender and the addressee.

Network (zonal) objectives are to optimize network or zone performance indicators, which can be determined by the following criteria: a minimum of service traffic, maximum of bandwidth, minimum of transmission power etc.

During the MANET operation these groups of objectives may conflict with each other. Therefore intellectual nodal control system has to coordinate and approve its management objectives with the nodes that will be involved when this node makes a decision.

Conclusions

The appearance of a new class of radio networks – MANET, their dimension increase, differences in nodes resources and appearance of new services require new hardware, architectural and scientific solutions to improve MANET efficiency.

In this paper a new approaches to the MANET functioning are offered. The main ones are: packets relay "on the fly", network topology management, implementation of the OSI-transport layer using route division into segments, parallel multiple packets retransmission, MANET intellectualization, OSI levels coordination, matching management objectives for network resource distribution.

Implementation of these approaches will create transport basis for building of the new generation radio that will allow providing quality communications to subscribers according to the principle "in any place – at any time".

References

1. Romanjuk V.A. Tactical radionetworks evolution // In Proceeding of VI Scientific and Practical Seminar „Priority areas of special purpose telecommunication systems and networks”. – Kyiv: VITI NTUU „KPI”, October 20, 2011. – P. 45 – 52.
2. Self organized radio networks with ultra wide band signals / [S.G. Bunin, A.P. Voyter, M.E. Ilchenko, V.A. Romanjuk]. – K.: SPE "Publishing house "Naukova Dumka" National Academy of Sciences of Ukraine", 2012. – 444 p.
3. Tactical Radios// Compendium by Armada. – August, 2012. – Access mode: <http://www.armada.ch/wp-content/uploads/2013/01/Compendium-TACTICAL-RADIO-Aug-Sept-2012.pdf>.
4. Radios // Compendium by Armada. – October 2013. – Access mode: <http://www.armada.ch/wp-content/uploads/2013/12/Armada-Oct-Nov-2013-Compendium-Radio.pdf>.
5. Redi J., Ramanathan R. The DARPA WNaN Network Architecture // In IEEE Proceeding MILCOM, 2011.
6. Li L., Lamont L. Support real-time interactive session applications over a tactical mobile ad-hoc networks // In IEEE Proceeding MILCOM, 2005.
7. Wang H., Crilly B., Zhao W., Autry C., Swank S. Implementation Mobile Ad-hoc Networks over legacy tactical radio links// In IEEE Proceeding MILCOM, 2007.
8. Suman B., Sharma S., Kumar M. Investigation communication architecture for tactical radio networks design // IJREAS Volume 2, Issue 2, 2012.
9. Ramanathan R. A Radically New Architecture for Next Generation Mobile Ad Hoc Networks // In IEEE Proceeding MOBICOM, 2005.
10. Romanjuk V.A., Minochkin A.I. Mobile radio network topology management // *Zv'yazok*. – 2003. – № 2. – P. 28 – 33.
11. Romanjuk V.A. The tactical radio networks operative management system architecture // *Zbirnik naukovih prats` VITI NTUU “KPI”*. – 2009. – № 3. – P. 70 – 76.
12. Romanjuk V.A., Minochkin A.I. Multi-path routing in mobile radio networks // *Zv'yazok*. – 2004. – № 6. – P. 38 – 46.
13. Romanjuk V.A. Objective functions of tactical radio networks operational management // *Zbirnik naukovih prats` VITI NTUU “KPI”*. – 2012. – № 1. – P. 109 – 117.

Received in final from June __, 2014